

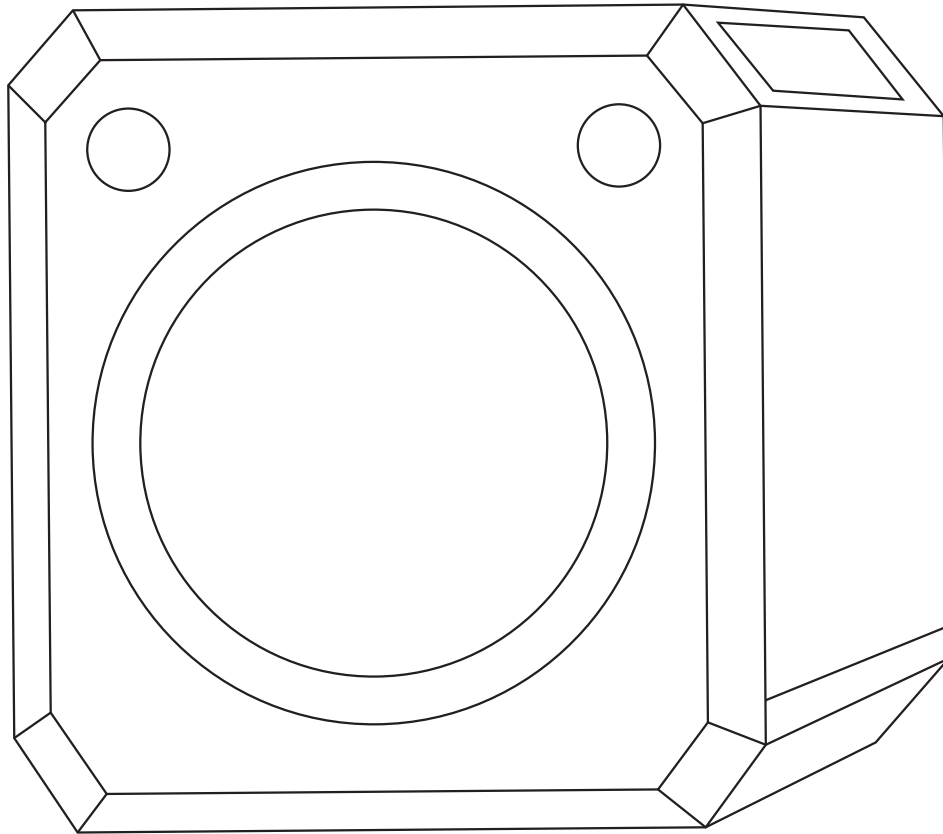

Aerus PowerPure[®]



AP03 HEPA Air Purifier & Ultrasonic Humidifier

CAUTION: READ MANUAL CAREFULLY FOR PROPER PROCEDURES AND OPERATION.

INTRODUCTION

Thank you for purchasing your new Aerus PowerPure® AP03 HEPA Air Purifier & Ultrasonic Humidifier!

This combination humidifier and air purifier has the two primary functions operate independently so that you can purify the air all year and then humidify only when needed in the dry months.

The Aerus PowerPure® AP03 features quiet HEPA air purification as well as a robust granulated carbon filter for the reduction of VOCs such as Formaldehyde, cooking odors and other chemicals. The Aerus PowerPure AP03 is designed for both living and sleeping areas and purifies and humidifies any area up to 400 sq. ft.

We wish you many years of clean air and humidification with this high-quality appliance. Please read this owner’s manual to fully understand all of the operational features and safety instructions for the unit.

If you have any questions concerning this product, contact Aerus Customer Service by calling toll free 1-888-764-0693 or via email at support@aerusonline.com.

TABLE OF CONTENTS

Introduction.....	2
Product Specifications	3
Important Safety Instructions	4
Operational Placement & Parts Diagram	5
Getting Started	6, 7
Control Panel/ Product Operation	8
Features.....	9
Odor Sensor.....	10
Product Maintenance	11
Troubleshooting	12
Warranty	13, 14

	CORRECT DISPOSAL OF THIS PRODUCT
	<p>This marking indicates that this product should not be disposed with other household wastes throughout the EU. To prevent possible harm to the environment or human health from uncontrolled waste disposal, recycle it responsibly to promote the sustainable reuse of material resources. To return your used device, please use the return and collection systems or contact the retailer where the product was purchased. They can take this product for environmental safe recycling.</p>

Please recycle per local city/country/state laws in the U.S.

SPECIFICATIONS

Model:	AP03
Rated Voltage:	120VAC
Rated Frequency:	60Hz
Rated Power:	Air Purifier: 35 watts Humidifier: 18 watts
Rated Airflow:	124 cfm
CADR value (CFM) (0.583*m3/h=1cfm)	5,650 ft ³ per hour (94 CFM)
Air Purification Efficiency (PM 2.5)*	99%
Coverage Area	Up to 400 sq. ft.
Weight	13.8 lbs.
Dimensions	13.7"L x 12.24"W x 12.87"H
Water Tank Capacity	1 gallon
Maximum Humidification Output	2 gallons per 24 hours

Each of the performance parameters in the above chart is measured before the machine leaves the factory according to the effective GB/T 18801, GB4706.1 and GB4706.45.

*PM 2.5 defined: Particulate matter, or PM, is the term for particles found in the air, including dust, dirt, soot, smoke, and liquid droplets. Particles can be suspended in the air for long periods of time. Some particles are large or dark enough to be seen as soot or smoke. Others are so small that individually they can only be detected with an electron microscope.

Particles that measure less than 10 micrometers in diameter (PM10) pose a health concern because they can be inhaled into and accumulate in the respiratory system. Particles less than 2.5 micrometers in diameter (PM 2.5) are referred to as "fine" particles and are believed to pose the greatest health risks. Because of their small size (approximately 1/30th the average width of a human hair), fine particles can lodge deeply into the lungs.**

**Excerpt borrowed from www.epa.gov/particle-pollution-designations/learn-about-particle-pollution-designations#process. Learn more about PM 2.5 from the United States EPA.

IMPORTANT SAFETY INSTRUCTIONS

READ ALL INSTRUCTIONS BEFORE USING THIS PRODUCT

 **WARNING:** Important Safety Instructions to reduce the risk of fire, electrical shock, or injury.

 **WARNING:** Only use the Aerus PowerPure® AP03 HEPA Air Purifier & Ultrasonic Humidifier indoors. Improper use can be hazardous for your health and can lead to injury.

Your safety and the safe operation of this air purifier and humidifier are very important to us. All safety and operating instructions should be read, adhered to and followed before the unit is operated. Incorrect operation may cause harm or damage.

- Repairs to the unit should only be made by a qualified, professional and authorized repairman. Improper repair work can cause danger to the user
- Make sure air purifier is powered off and unplugged from the wall outlet before moving the unit
- To prevent damage, remove all packaging from the air purifier prior to turning on the unit
- Only operate the air purifier when it is fully assembled
- Do not use outdoors or on wet surfaces
- Place the air purifier on a hard protective (waterproof) surface to ensure optimal performance, prevent tipping and damage to flooring or furniture
- Make sure there is at least 8 inches between the air inlet on the bottom of the air purifier and objects within the room
- Do not wring, pinch, bend, or twist the power cord
- Do not drag the power cord when it is disconnected from the wall outlet
- Never use the air purifier if there is damage to the unit or the power cord
- To avoid electrical shock, do not touch the air purifier, power cord or plug when your hands are wet
- Only connect the air purifier to a 110-120V power source – do not use with other equipment
- Only use the power cord that came with the unit
- Always unplug the air purifier before moving the air purifier or changing the filter
- Do not use the air purifier if it is making an abnormal sound or has an abnormal smell
- Do not put fingers or any foreign objects into the inlet or outlet of the air purifier, as this can cause electric shock or damage to the humidifier
- Keep hair, clothing or loose items away from the air purifier to prevent injury
- Do not sit on, lean against or tilt the main body of the air purifier
- Do not use in rooms where there is high moisture or water, such as a bathroom
- Do not allow air purifier to be used as a toy. Close supervision is necessary when operated near children

SAVE THESE INSTRUCTIONS

OPERATIONAL PLACEMENT & PARTS DIAGRAM

OPERATIONAL PLACEMENT:

The AP03 should be placed on the floor in the center or corner of a room. It should be placed at least 8 inches away from the wall—its airflow design requires adequate clearance between the air purifier and the wall to allow the purified air to thoroughly circulate through the room. Please avoid placing the AP03 in front of a centralized heating return or another type of heating source. Choose a location that is close to a power outlet for easy connection to the electrical source (the power cord length is 5.9 ft.).

PARTS DIAGRAM:

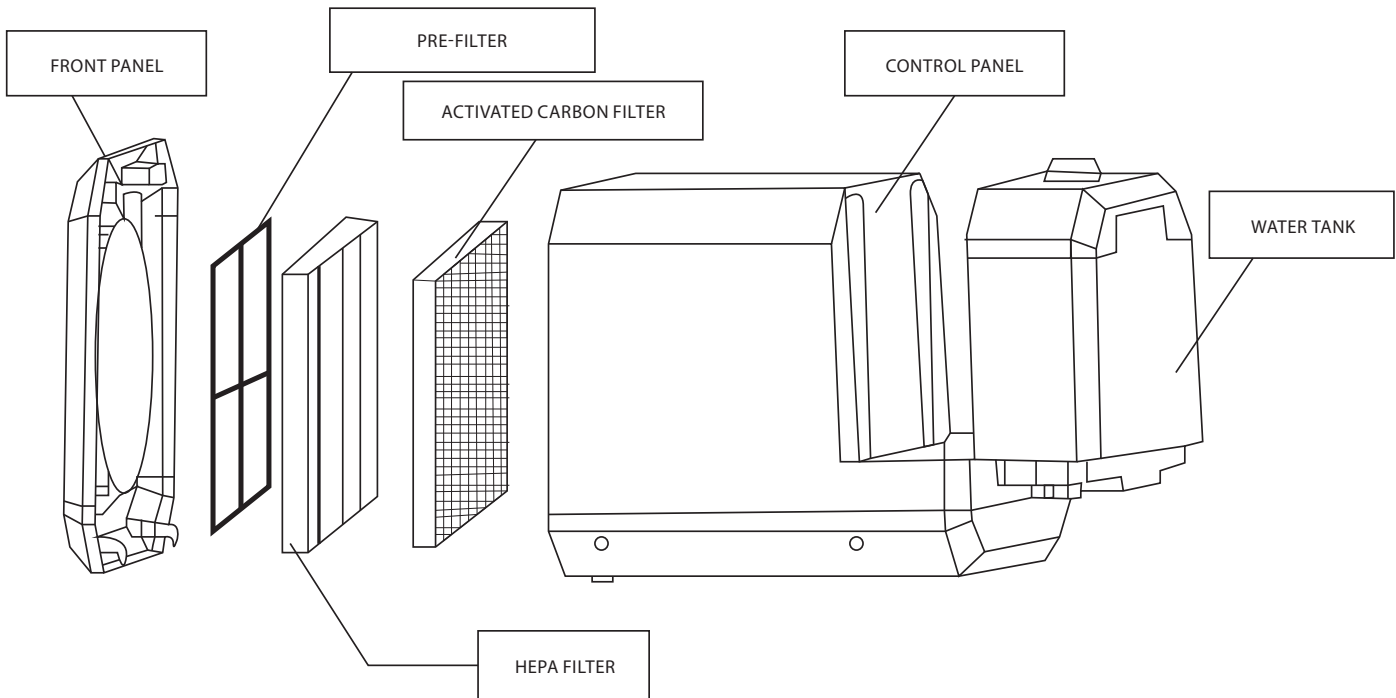

GETTING STARTED

NOTE: Before using your purifier/humidifier, remove all packaging from the filters.

 **WARNING:** Disconnect plug from power source!

Step 1: Open the front panel. To do this, hold the top of the front panel on the upper left- and right hand side of the front panel with both hands, then pull the panel towards you until it is fully removed from the main body of the unit.

Step 2: Remove the Pre-Filter, HEPA Filter and Activated Carbon Filter from the unit. Completely remove all of the packaging from each filter.

Step 3: Insert the filters back into the filter cavity in this order:

1. Insert the Activated Carbon Filter, front side facing out.
2. Insert the HEPA filter, front side facing out.
3. Insert the Pre-Filter by bowing slightly and inserting Tabs into one side and then into the other side.

Step 4: Reinsert and close the front panel. Do this by inserting the lower part of the front panel into the two bottom holes on the unit (see drawing 1 below) and raise the lid upwards until it closes. The front panel is secured with magnets (see drawing 2 below).

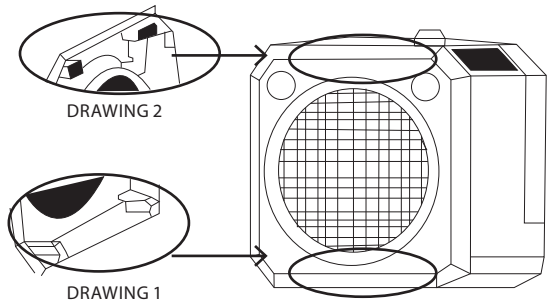
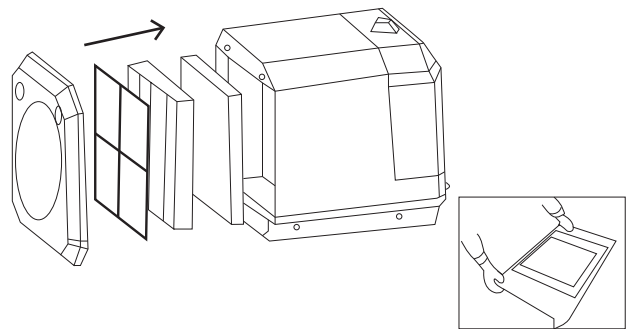
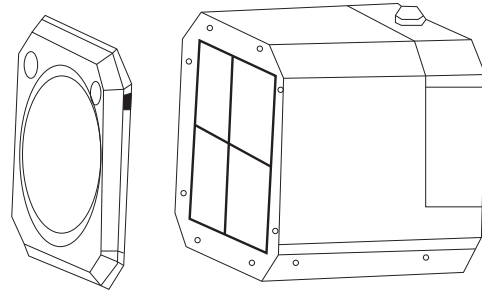
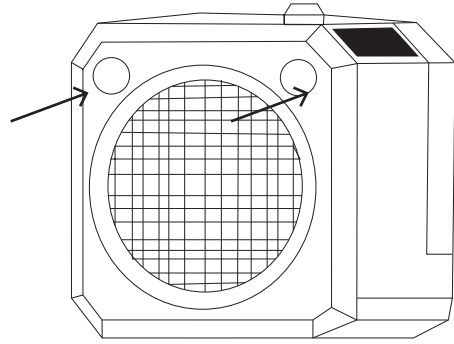

GETTING STARTED (CONTINUED)

HOW TO ADD WATER TO THE WATER TANK FOR HUMIDIFICATION:

 **WARNING:** Disconnect plug from power source!

Step 1: Put your finger inside the lifting yoke and lift up the water tank to remove.

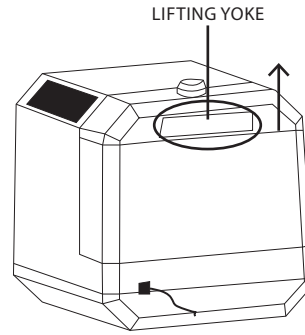

Step 2: Turn the water tank upside down and remove the cap by turning counter clockwise.

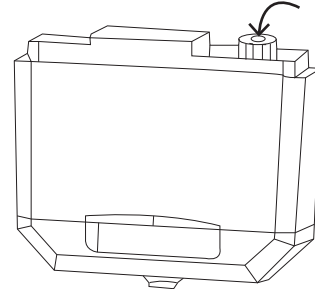

Step 3: Fill the water tank with water.

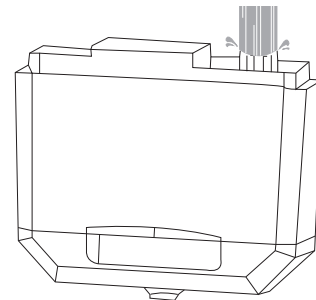

Step 4: Replace the cap and rotate clockwise to tighten, making sure it is tight to ensure a waterproof seal.

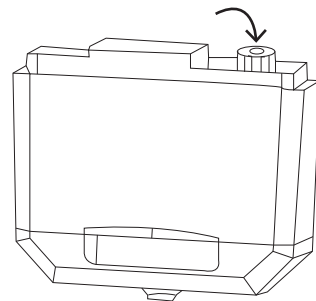

Step 5: Carefully place the water tank back onto the unit, making sure the inner tabs match up with the slots in the base.

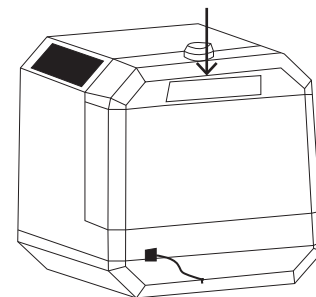

NOTES:

- Always add clean, cool water to water tank
- If the water tank runs out of water, add more water to maintain desired humidity

CONTROL PANEL/ PRODUCT OPERATION

ON/OFF BUTTON

Press the ON/OFF button to turn the Aerus PowerPure AP03 on or off. The AP03 always starts in Purification mode, low speed.

PURIFICATION BUTTON

Press the PURIFICATION button to control the fan speed while in Purification mode. Use this button to toggle between Low, Medium, High, or Off.

HUMIDIFICATION BUTTON

Press the HUMIDIFICATION button to control the humidifier. Use this button to toggle between Low, High, or Off. When activated, the humidifier always starts in high humidification mode.

NOTE: When the tank is empty, the HUMIDIFICATION button will blink three times and turn off.

FILTER RESET BUTTON

Press and hold the FILTER RESET button for three seconds to turn off and reset the Filter Reset indicator AFTER the filters have been replaced.

- Replace the HEPA Filter and Active Carbon Filter approximately every six months.
- Please note that depending upon environmental conditions, the filters may need to be changed more frequently.

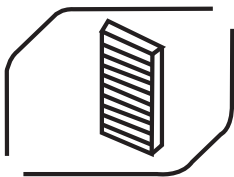

Filter Reset



Humidification



Purification

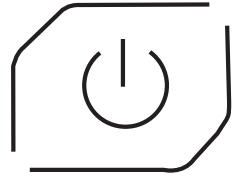

ON/OFF

FEATURES

PRODUCT OVERVIEW:

The Aerus PowerPure AP03 is a combination air purifier and ultrasonic humidifier that utilizes a Pre-Filter, HEPA Filter and an Activated Carbon Filter to reduce contaminants and other volatile organic compounds (VOCs), plus other allergens and irritants including smog, pollen, dust, mold, pet dander, and odor-causing bacteria. Air is drawn in through the intake cover at the front of the air purifier and then it is purified by passing through the Pre-Filter, HEPA Filter and Activated Carbon Filter. The AP03 can be operate as an air purifier or a humidifier, or both simultaneously.

FEATURES:

Three-Stage Air Purification System:

- **Pre-Filter (stage 1):** for the removal of large, course particles.
- **High-Efficiency HEPA Filter (stage 2):** for the removal of microscopic particles.
- **Activated Carbon Filter (stage 3):** for the removal of contaminants such as VOCs and other common household odors.

Ultrasonic Humidifier:

- The appliance features an ultrasonic humidifier that enables you to achieve proper humidity levels in your home. It will humidify spaces up to 400 square feet in size.
- The humidifier will automatically turn off when the water level is low.

Filter Reset Indicator:

- There is a Filter Reset indicator located on the control panel that lets you know when the HEPA and Activated Carbon Filters need to be replaced.

Speed Options:

- **Three Airflow Speeds:** High, Medium, and Low.

Other Intelligent Functions:

- **Surge Protection Feature** — the unit will automatically turn off the electrical current in the event of an electrical surge.

PRODUCT MAINTENANCE



WARNING: Disconnect plug from power source before cleaning the exterior or the water tank.

CLEANING THE APPLIANCE

- **Cleaning the Exterior:** Wipe the sides of the unit with a damp cloth to remove any dirt or stains on the surface of the appliance.
- **Cleaning the Water Tank:** Clean the water tank with water and the included cleaning brush. Then use a soft cloth to remove any lime scale that may have built up in the basin. We advise cleaning the water tank every 2-3 weeks depending upon use.

WHEN TO REPLACE OR CLEAN THE FILTERS

- **Pre-Filter:** Clean at least every 2 months (based upon a run time of 24 hours per day). To clean the Pre-Filter, rinse it under a faucet and allow it to dry completely before placing it back into the appliance. As part of general maintenance, the Pre-Filter should be evaluated and cleaned every two months if there is a build-up covering the filter.
- **HEPA Filter:** Replace approximately every 6 months (based upon a run time of 24 hours per day). The Filter Reset light will illuminate red, prompting you to change the HEPA Filter.
- **Active Carbon Filter:** Replace approximately every 6 months (based upon a run time of 24 Hours per day). The Filter Reset light will illuminate red, prompting you to change the Active Carbon Filter.

NOTE: The HEPA and Active Carbon Filters cannot be washed. Please discard these filters and replace them with brand-new filters when they reach end of life. Depending upon environmental conditions, the filters may need to be changed more frequently.

PURCHASING REPLACEMENT FILTERS

To purchase replacement filters contact Aerus Customer Service by calling toll free 1-888-764-0693 or via email at support@aerusonline.com.

TROUBLESHOOTING

⚠ WARNING: Please do not disassemble the air purifier or service yourself. If these corrective actions do not solve the problem, please contact Aerus Customer Service by calling toll free 1-888-764-0693 or via email at support@aerusonline.com.

POSSIBLE ISSUE	POSSIBLE REASONS	WHAT TO DO
The unit stops running	<ol style="list-style-type: none"> 1. The power cord is not plugged in properly to the wall. 2. The "On" button on the AP03 has not been pressed. 	<ol style="list-style-type: none"> 1. Connect the cord to the wall outlet and make sure the plug is inserted securely. 2. Press the "On" button on the control panel to turn the unit on.
Decreased particulate or odor removal	<ol style="list-style-type: none"> 1. HEPA and Activated Carbon Filter are not installed properly for correct airflow. 2. Activated Carbon Filter has expired and needs to be replaced. 3. Inspect filters to ensure there is no blockage of foreign matter. 	<ol style="list-style-type: none"> 1. Ensure the HEPA and Activated Carbon Filters are inserted correctly and facing the correct direction within the unit. 2. Replace the Activated Carbon Filter. 3. Remove any foreign matter from the air intake.
Filter Reset light is illuminated.	<ol style="list-style-type: none"> 1. The HEPA and Active Carbon Filters have not been replaced. 	<ol style="list-style-type: none"> 1. Replace the HEPA and Active Carbon Filters and make sure they were inserted correctly into the unit. 2. Press and hold the FILTER RESET button to reset the Filter Reset indicator once you've replaced the filter(s).

LIMITED 1 YEAR WARRANTY

Customer should not repackage and ship the Aerus PowerPure AP03 unit due to possibility of irreparable damage. For warranty service, please contact Aerus Customer Service by calling 1-888-764-0693 or via email at support@ aerusonline.com.

WHAT IS COVERED BY THIS WARRANTY

We warrant the Aerus PowerPure AP03 to the Customer, subject to the conditions herein, against defects in workmanship and material, for a period of one (1) year from the date of Customer's original retail purchase.

INSTALLATION AND MAINTENANCE REQUIREMENTS

This warranty is expressly conditioned upon proper installation, operation, cleaning, and maintenance, all in accordance with the Owner's Manual. Failure to meet any of these requirements will void this warranty. Servicing of your Aerus PowerPure AP03 by parties other than our authorized representatives and/or using parts other than genuine parts will also void this warranty.

HOW TO OBTAIN WARRANTY SERVICE

Customer must contact Aerus Customer Service by calling 1-888-764-0693 or via email at support@aerusonline.com and provide proof of purchase within the above time periods. We will repair or replace and return the product, without charge and within a reasonable period of time, subject to the conditions herein, if our examination shall disclose any part to be defective in workmanship or material. If we, in our discretion, are unable to repair the product after a reasonable number of attempts, we will provide either a refund of the purchase price or a replacement unit, at the company's option. WE reserve the right to inspect and/or require conformation of installation method.

WHAT IS NOT COVERED BY THIS WARRANTY

Not for commercial use. Ordinary wear and tear shall not be considered a defect in workmanship or material. These warranties do not apply for loss or damage caused by accident, fire, abuse, misuse, improper installation, leaking, modification, misapplication, or any repairs other than those provided by our authorized Service Center. This warranty is non-transferable and does not cover consumable items such as filters.

UNAUTHORIZED CHANNELS

Warranties are voided if a product is purchased through unauthorized channels; this includes websites that are not authorized to use our trademarked names, images, and logos as well as Internet auction sites (e.g. eBay and Craigslist). To confirm warranty coverage prior to purchasing a product, contact Customer Service with the product serial number.

EXCLUSION OF OTHER WARRANTIES & CONDITIONS

EXCEPT AS PROVIDED HEREIN, WE MAKE NO REPRESENTATION OR WARRANTY OF ANY KIND. ALL OTHER WARRANTIES OF ANY KIND, EXPRESS OR IMPLIED, ARE HEREBY EXPRESSLY DISCLAIMED, INCLUDING ANY IMPLIED WARRANTY OF MERCHANTABILITY OR FITNESS FOR A PARTICULAR PURPOSE.

LIMITATION OF LIABILITY FOR SPECIAL, INCIDENTAL, OR CONSEQUENTIAL DAMAGES

WE SHALL NOT IN ANY CASE BE LIABLE FOR SPECIAL, INCIDENTAL, OR CONSEQUENTIAL DAMAGES ARISING FROM BREACH OF EXPRESSED OR IMPLIED WARRANTIES, CONDITIONS, GUARANTEES, OR REPRESENTATIONS, BREACH OF CONTRACT, NEGLIGENCE, OR ANY OTHER LEGAL THEORY. Such excluded damages include, but are not limited to, loss of profits or revenue, and loss of the use of the products, and any loss caused by leaks or other water damage.

LIMITED 1 YEAR WARRANTY (CONTINUED)

FOR U.S. APPLICATION ONLY

This warranty gives you specific legal rights, and you may also have other rights which vary from state to state. Some states do not allow limitations on warranties, or on remedies for breach. In such states, the above limitations may not apply to you.

FOR CANADIAN APPLICATION ONLY

Exclusion of Subsequent Owners: Except as otherwise required by applicable legislation, this warranty is not transferable. This warranty gives you specific legal rights and you may also have other rights which vary from province to province. Some provinces and territories do not allow limitations on warranties, or on remedies for breach. In such provinces or territories, the above limitations may not apply to you.

If any provision of this warranty or part thereof is held by a court of competent jurisdiction to be invalid, illegal, or unenforceable, the validity, legality and enforceability of the remaining provisions or parts thereof will not in any way be affected or impaired within the jurisdiction of that court. This entire warranty shall continue to be valid, legal, and enforceable in any jurisdiction where a similar determination has not been made.

This warranty is provided by:

Aerus Health Direct, LLC
300 East Valley Drive
Bristol, VA 24201 (in US)

Aerus Canada, Inc.
3480 Laird Road, Suite 25
Mississauga, Ontario L5L 5Y4

SERVICE

Every effort is made to ensure customers receive an up-to-date owner's manual on the use of our products; however, from time to time, modifications to our products may without notice make the information contained herein subject to alteration. For the latest information, please visit our website.

This equipment has been tested and found to comply with the limits for Industrial, Scientific, and Medical Equipment (ISM), pursuant to Part 18 of the FCC Rules. These limits are designed to provide reasonable protection against harmful interference in a residential installation. This equipment generates, uses, and can radiate radio frequency energy, and if not installed and used in accordance with the instructions, may cause harmful interference to radio communications. However, there is no guarantee that interference will not occur in a particular installation. If this equipment does cause harmful interference to radio or television, which can be determined by turning the equipment off and on, the user is encouraged to try to correct the interference by one or more of the following measures:

Reorient or relocate the receiving antenna. Increase the separation between the equipment and receiver.

Connect the equipment into an outlet on a circuit different from that to which the receiver is connected.

Consult Customer Service or an experienced radio/TV technician for help.

FCC DECLARATION OF CONFORMITY

Name: Aerus Health Direct, LLC

Model: Aerus PowerPure AP03

Manufacturer: Aerus Health Direct, LLC

This device complies with Part 18 of the FCC Rules.

RESPONSIBLE PARTY

Aerus Health Direct, LLC
300 East Valley Drive
Bristol, VA 24201
Ph: 888-764-0693

Signature:



Printed Name: Andrew Eide

Title: Vice President of Product Development & Manufacturing

Date: 12/19/17



www.PowerPure.com

For information regarding the use of this product contact Customer Service.

support@aerusonline.com

(888) 764-0693

Aerus Health Direct, LLC 300 East Valley Drive, Bristol, VA 24201
Made in P.R.C ©Aerus Health Direct, LLC 2017